

RADSAN

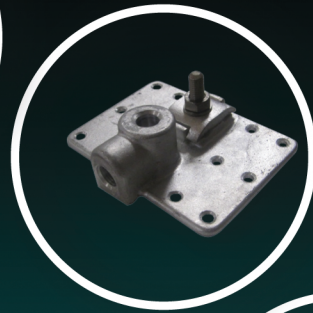

WIL

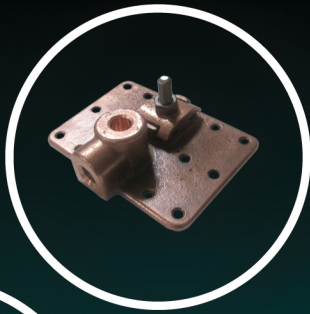
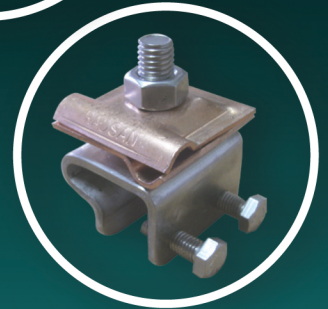

catalogue

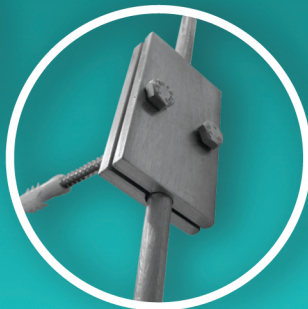

Lightning Protection & Grounding



RAD SAN

u l k a t a l o g
c a t a l o g u e

Kasım 2011
Ankara-Türkiye



INDEX

Points	2
-Vertical / Horizontal Mount Point Bases	
Point Bases	3 - 4
-Vertical / Horizontal Mount Point Bases	
-Ridge / Sloping Roof Point Base	
-Adjustable Point Adapters	
-Dowel For Adjustable Point Adapters	
Point Bases	5 - 6
-Vertical / Horizontal Mount Point Bases	
-Standing Seam Bases	
Cable Fasteners	7
Clips / Conductor Holder	8 - 12
-Pipe / Mast Type	
-Pipe & Mast Clamp "Insulated"	
-Gutter / Parapet / Handrail / Profile / Busbar Conductor Holder	
-Roof Conductor Holder	
-Conductor Holders	
Connectors	12
-2-Way Connector	
-4-Way Connector	
-Jaw (Nail) Connector	
-Pipe Clamps	
Test Clamps	14
-Jaw (Nail) Connector	
Earth Bars	14
Earth Point Assembly	15
-Body	
-Hook	
-Connector	
Earth Points	15
Protected Bar	16
Telecommunications - Main Grounding Busbars TMGB	17
Pointed Ground Rods	18
Sectional Ground Rods	19
Copper Plated Steel Earth Rod (1000µm)	20
Copper Plated Steel Earth Rod (3000µm)	20
Connection Box, Pits	21
Eritech Copperbonded Ground Rods Standard Type	22
Cadweld	22
Cadweld Plus	23
Cadweld And Cadweld Plus	24
Cadweld Multi	25 - 30



POINTS

ACCORDING TO CLASS 1 & CLASS 2



Sira No Code	LENGHT	CLASS 1		CLASS 2		
		COPPER 3/8"	AL 1/2"	COPPER 1/2"	COPPER 5/8"	AL 5/8"
1	10'	ULPC-3801	ULPA-1201	ULPC-1201	ULPC-5801	ULPA-5801
2	12'	ULPC-3802	ULPA-1202	ULPC-1202	ULPC-5802	ULPA-5802
3	15'	ULPC-3803	ULPA-1203	ULPC-1203	ULPC-5803	ULPA-5803
4	18'	ULPC-3804	ULPA-1204	ULPC-1204	ULPC-5804	ULPA-5804
5	24'	ULPC-3805	ULPA-1205	ULPC-1205	ULPC-5805	ULPA-5805
6	30'	ULPC-3806	ULPA-1206	ULPC-1206	ULPC-5806	ULPA-5806
7	36'	ULPC-3807	ULPA-1207	ULPC-1207	ULPC-5807	ULPA-5807
8	48'	ULPC-3808	ULPA-1208	ULPC-1208	ULPC-5808	ULPA-5808



ACCORDING TO POINT DIAMETER

Sira No Code	LENGHT	3/8" POINT		1/2" POINT		5/8" POINT	
		CU (CLASS 1)	AL (CLASS 1)	CU (CLASS 2)	AL (CLASS 2)	CU (CLASS 2)	AL (CLASS 2)
1	10'	ULPC-3801	ULPA-1201	ULPC-1201	ULPA-1201	ULPC-5801	ULPA-5801
2	12'	ULPC-3802	ULPA-1202	ULPC-1202	ULPA-1202	ULPC-5802	ULPA-5802
3	15'	ULPC-3803	ULPA-1203	ULPC-1203	ULPA-1203	ULPC-5803	ULPA-5803
4	18'	ULPC-3804	ULPA-1204	ULPC-1204	ULPA-1204	ULPC-5804	ULPA-5804
5	24'	ULPC-3805	ULPA-1205	ULPC-1205	ULPA-1205	ULPC-5805	ULPA-5805
6	30'	ULPC-3806	ULPA-1206	ULPC-1206	ULPA-1206	ULPC-5806	ULPA-5806
7	36'	ULPC-3807	ULPA-1207	ULPC-1207	ULPA-1207	ULPC-5807	ULPA-5807
8	48'	ULPC-3808	ULPA-1208	ULPC-1208	ULPA-1208	ULPC-5808	ULPA-5808

- Manufactured from highly conductive electrolytic copper
- Utilizes standard 3/8", 1/2", 5/8" UNC threads.. Manufactured from highly conductive aluminum.
- Utilizes standard 1/2", 5/8" UNC threads.

Please add "S" For Safety Tip. Ex, and "N" for Ni. plated Cu, and "T" tin plated Cu
 Example: ULPC-3807S-N, ULPC-3807-N

Class I air terminals are used on structures up to and including 75' (23m) tall. Class II air terminals are used on structures greater than 75' in height

POINT BASES

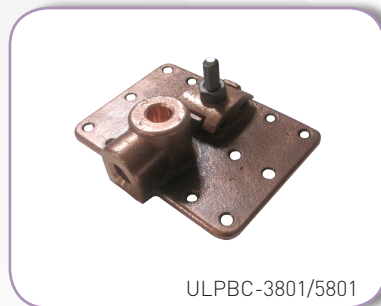

Vertical / Horizontal Mount Point Bases

COPPER	
Code	Code
POINT DIA. 3/8"	POINT DIA. 5/8"
ULPBC-3801	ULPBC-5801
ULPBC-3802	ULPBC-5802

- **222x333** mm base features a universal mounting design allowing it to be installed either horizontally or vertically.
- Utilizes a variety of mounting applications such as self tapping screws, nails or adhesives.
- Accepts all Class I & Class II conductors.
- **Manufactured from** Bronze, Electro Tin Plated Bronze, aluminum as cast



POINT BASES

Vertical / Horizontal Mount Point Bases

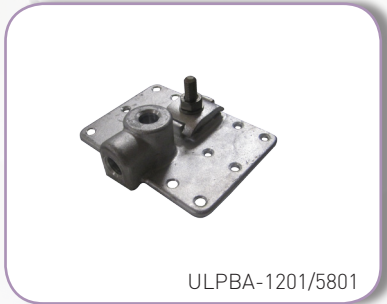

ALUMINUM	
Code	Code
POINT DIA. 1/2"	POINT DIA. 5/8"
ULPBA-1201	ULPBA-5801
ULPBA-1202	ULPBA-5802

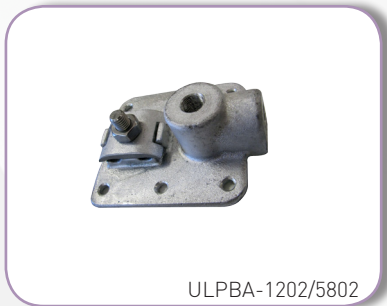

Please add "T", electro tin plated cast copper base

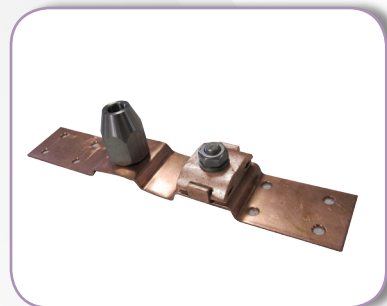

Ridge / Sloping Roof Point Base

POINT DIA.	COPPER	ALUMINUM
	Code	Code
3/8"	PBCR-3801	XXXXXX
1/2"	PBCR-1201	PBAR-1201
5/8"	PBCR-5801	PBAR-5801



Please add "T", tin plated copper base

Manufactured from highly conductive electrolytic copper sheet

Manufactured from highly conductive aluminum sheet & Stainless steel



Adjustable Point Adapters



ST. STEEL	COPPER	ALUMINUM
Code	Code	Code
PAS-3801	PAC-3801	XXXXXX
PAS-1201	PAC-1201	PAA-1201
PAS-5801	PAC-5801	PAA-5801



- Manufactured from highly conductive copper, **aluminium and** stainless steel
- Utilizes standard 3/8", 1/2", 5/8" UNC threads..

Dowel For Adjustable Point Adapters

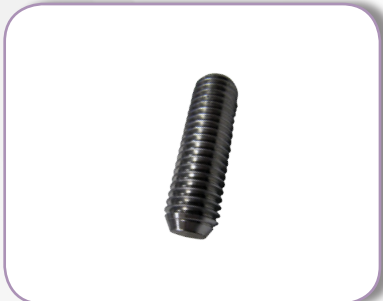

DIA.	STAINLESS STEEL
Code	Code
3/8"	DPA-3801
1/2"	DPA-1201
5/8"	DPA-5801





POINT BASES

Vertical & Horizontal Mount Point Bases



11 SERIES



11 SERIES

COPPER	
POINT DIA. 3/8"	POINT DIA. 5/8"
Code	Code
PBHC-3811	PBHC-5811
PBVC-3811	PBVC-5811

Manufactured from highly conductive electrolytic copper sheet & stainless steel



11 SERIES



11 SERIES

ALUMINUM	
POINT DIA. 1/2"	POINT DIA. 5/8"
Code	Code
PBHA-1211	PBHA-5811
PBVA-1211	PBVA-5811

Manufactured from highly conductive aluminum sheet & stainless steel



POINTS BASES

Vertical & Horizontal Mount Point Bases

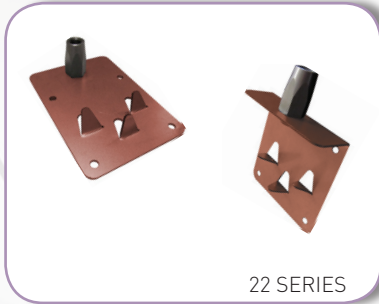

COPPER	
POINT DIA. 3/8"	POINT DIA. 5/8"
Code	Code
PBHC-3822	PBHC-5822
PBVC-3822	PBHC-5822



ALUMINUM	
POINT DIA. 1/2"	POINT DIA. 5/8"
Code	Code
PBHA-1222	PBHA-5822
PBVA-1222	PBVA-5822

STANDING SEAM BASES

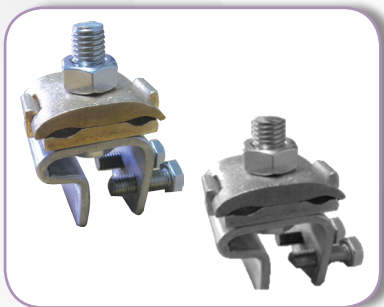

Code	Material/Coating	Point Dia.
PBSSA-01	Aluminium	5/8"
PBSSC-01	Copper	5/8"

Manufactured from highly conductive cast aluminum & bronze

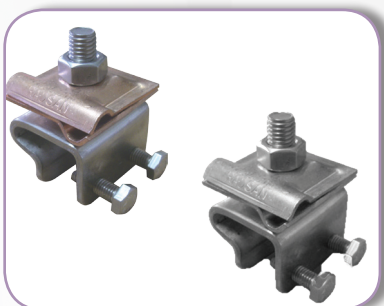

Code	Material/Coating	Point Dia.
PBSSA-11	Aluminium	5/8"
PBSSC-11	Copper	5/8"

Manufactured from highly conductive aluminum & stainless steel sheet



CABLE FASTENERS



COND. DIA	MATERIAL	
	COPPER Code	ALUMINUM Code
8	IKC-1101	IKA-1101
10	IKC-1102	IKA-1102
12	IKC-1103	IKA-1103
14	IKC-1104	IKA-1104

Manufactured from highly conductive aluminum & copper sheet

CLIPS / CONDUCTOR HOLDER



Clips

Wire Dia.	CLASS 1		CLASS 2	
	Cu	Al	Cu	Al
	Code			
3 / 8"	CFC-38			
7 / 16"	CFC-716	CFA-716		
1 / 2"		CFA-12	CFC-12	
9 / 16"				CFA-916
19 / 32"				CFA-1932

Two - Hole Clip

Code	Material/Coating	Wire Dia.
IK.102.01	Cu-Al-Ssteel	3/8"
IK.102.02	Cu-Al-Ssteel	7/16"
IK.102.03	Cu-Al-Ssteel	9/16"

Manufactured from highly conductive aluminum & copper sheet





CLIPS / CONDUCTOR HOLDER



Code	Material/Coating	Wire Dia.
IK.104.01	Cu - Al - Ssteel	3/8"
IK.104.02	Cu - Al - Ssteel	7/16"
IK.104.03	Cu - Al - Ssteel	9/16"



Code	Material/Coating	Wire Dia.
IK.115.31	Al-Al, Cu+Sn-Al	3/8"
IK.115.32	Al-Al, Cu+Sn-Al	7/16"
IK.115.33	Al-Al, Cu+Sn-Al	9/16"



Code	Material/Coating	Wire Dia.
IK.115.04	Al-Al, Cu+Sn-Al	3/8"
IK.115.05	Al-Al, Cu+Sn-Al	7/16"
IK.115.06	Al-Al, Cu+Sn-Al	9/16"

Holder(upper part):Manufactured from highly conductive aluminum & copper sheet
Body&screw:Al+stainlesssteel



Code	Material	Bolt	Cross-section
IK.107.04	[A+D1]-[A+D2]-[A+N]-[B+D1]-[B+D2] [B+N]-[D1+D1]-[D2+D2]-[N+N]	DC-NC	1x50 mm ²
IK.107.05	[A+D1]-[A+D2]-[A+N]-[B+D1]-[B+D2] [B+N]-[D1+D1]-[D2+D2]-[N+N]	DC-NC	1x70 mm ²
IK.107.06	[A+D1]-[A+D2]-[A+N]-[B+D1]-[B+D2] [B+N]-[D1+D1]-[D2+D2]-[N+N]	DC-NC	1x95 mm ²
IK.107.07	[A+D1]-[A+D2]-[A+N]-[B+D1]-[B+D2] [B+N]-[D1+D1]-[D2+D2]-[N+N]	DC-NC	1x120 mm ²

MAIN MATERIAL
A=Aluminium, B=Copper, D=Iron-Steel,
F=Bronze, G=Gray Cast Iron,
N=Stainless, P=Plastic, S=Brass

COATINGS
1=Electrogalvanizing, 2=Hot Dip Galvanizing,
3=Electrodeposited Copper, 4=Electrodeposited Tin,
5=Electrodeposited Chromium-Nickel,
6=Black Insulation, 7=Yellow-Green Insulation

SCREW NUT
DC=Galvanizing,
NC=Stainless,
SC=Brass



CLIPS / CONDUCTOR HOLDER

Pipe / Mast Type



Code	Material/Coating	Bolt	Dia. (inch)	Cross Section
IK.124.01	N	DC-NC	1/2"	1x120 mm ² ye kadar up to 1x120 mm ²
IK.124.02	N	DC-NC	3/4"	
IK.124.03	N	DC-NC	1"	
IK.124.04	N	DC-NC	1 1/4"	
IK.124.05	N	DC-NC	1 1/2"	
IK.124.06	N	DC-NC	2"	
IK.124.07	N	DC-NC	2 1/2"	



Code	Material/Coating	Bolt	Dia. (inch)
IK.126.01	D1-D2-N	DC-NC	1/2"
IK.126.02	D1-D2-N	DC-NC	3/4"
IK.126.03	D1-D2-N	DC-NC	1"
IK.126.04	D1-D2-N	DC-NC	1 1/4"
IK.126.05	D1-D2-N	DC-NC	1 1/2"
IK.126.06	D1-D2-N	DC-NC	2"
IK.126.07	D1-D2-N	DC-NC	2 1/2"



Code	Material/Coating	Bolt	Dia. (inch)	Cross Section
IK.127.01	D1-D2-N	DC-NC	1/2"	50 - 95 mm ²
IK.127.02	D1-D2-N	DC-NC	3/4"	50 - 95 mm ²
IK.127.03	D1-D2-N	DC-NC	1"	50 - 95 mm ²
IK.127.04	D1-D2-N	DC-NC	1 1/4"	50 - 95 mm ²
IK.127.05	D1-D2-N	DC-NC	1 1/2"	50 - 95 mm ²
IK.127.06	D1-D2-N	DC-NC	2"	50 - 95 mm ²
IK.127.07	D1-D2-N	DC-NC	2 1/2"	50 - 95 mm ²

MAIN MATERIAL
 A=Aluminium, B=Copper, D=Iron-Steel,
 F=Bronze, G=Gray Cast Iron,
 N=Stainless, P=Plastic, S=Brass

COATINGS
 1=Electrogalvanizing, 2=Hot Dip Galvanizing,
 3=Electrodeposited Copper, 4=Electrodeposited Tin,
 5=Electrodeposited Chromium-Nickel,
 6=Black Insulation, 7=Yellow-Green Insulation

SCREW NUT
 DC=Galvanizing,
 NC=Stainless,
 SC=Brass



CLIPS / CONDUCTOR HOLDER

Pipe & Mast Clamp "Insulated"



Code	Material / Coating	Bolt	Pipe Dia (inch)	Length
IKP.122.20.24	(A+A)-(D1+ B)-(D2+ B)-(N+ B)-(D1+D1)-(D2+D2)-(N+N)	DC-NC	2	2x50mm ²
IKP.122.20.25	(A+A)-(D1+ B)-(D2+ B)-(N+ B)-(D1+D1)-(D2+D2)-(N+N)	DC-NC	2	2x70mm ²
IKP.122.20.26	(A+A)-(D1+ B)-(D2+ B)-(N+ B)-(D1+D1)-(D2+D2)-(N+N)	DC-NC	2	2x95mm ²
IKP.122.20.31	(A+A)-(D1+ B)-(D2+ B)-(N+ B)-(D1+D1)-(D2+D2)-(N+N)	DC-NC	2	25x3mm
IKP.122.20.32	(A+A)-(D1+ B)-(D2+ B)-(N+ B)-(D1+D1)-(D2+D2)-(N+N)	DC-NC	2	35x3mm
IKP.122.25.24	(A+A)-(D1+ B)-(D2+ B)-(N+ B)-(D1+D1)-(D2+D2)-(N+N)	DC-NC	2 1/2	2x50mm ²
IKP.122.25.25	(A+A)-(D1+ B)-(D2+ B)-(N+ B)-(D1+D1)-(D2+D2)-(N+N)	DC-NC	2 1/2	2x70mm ²
IKP.122.25.26	(A+A)-(D1+ B)-(D2+ B)-(N+ B)-(D1+D1)-(D2+D2)-(N+N)	DC-NC	2 1/2	2x95mm ²
IKP.122.25.31	(A+A)-(D1+ B)-(D2+ B)-(N+ B)-(D1+D1)-(D2+D2)-(N+N)	DC-NC	2 1/2	25x3mm
IKP.122.25.32	(A+A)-(D1+ B)-(D2+ B)-(N+ B)-(D1+D1)-(D2+D2)-(N+N)	DC-NC	2 1/2	35x3mm
IKP.122.30.24	(A+A)-(D1+ B)-(D2+ B)-(N+ B)-(D1+D1)-(D2+D2)-(N+N)	DC-NC	3"	2x50mm ²
IKP.122.30.25	(A+A)-(D1+ B)-(D2+ B)-(N+ B)-(D1+D1)-(D2+D2)-(N+N)	DC-NC	3"	2x70mm ²
IKP.122.30.26	(A+A)-(D1+ B)-(D2+ B)-(N+ B)-(D1+D1)-(D2+D2)-(N+N)	DC-NC	3"	2x95mm ²
IKP.122.30.31	(A+A)-(D1+ B)-(D2+ B)-(N+ B)-(D1+D1)-(D2+D2)-(N+N)	DC-NC	3"	25x3mm
IKP.122.30.32	(A+A)-(D1+ B)-(D2+ B)-(N+ B)-(D1+D1)-(D2+D2)-(N+N)	DC-NC	3"	35x3mm

Gutter / Parapet / Handrail / Profile Busbar Conductor Holder



Code	Material/Coating	Bolt	Cross Section
IK.134.04	(A+D1)-(A+D2)-(A+N)-(B+D1)-(B+D2) (B+N)-(D1+D1)-(D2+D2)-(N+N)	DC-NC	1x50mm ²
IK.134.05	(A+D1)-(A+D2)-(A+N)-(B+D1)-(B+D2) (B+N)-(D1+D1)-(D2+D2)-(N+N)	DC-NC	1x70mm ²
IK.134.06	(A+D1)-(A+D2)-(A+N)-(B+D1)-(B+D2) (B+N)-(D1+D1)-(D2+D2)-(N+N)	DC-NC	1x95mm ²



Code	Material/Coating	Bolt	Cross Section
IK.117.04	(D1+A)-(D1+B)-(D1+D1)-(D2+A)-(D2+B) (D2+D2)-(N+A)-(N+B)-(N+N)	DC-NC	1x50 mm ²
IK.117.05	(D1+A)-(D1+B)-(D1+D1)-(D2+A)-(D2+B) (D2+D2)-(N+A)-(N+B)-(N+N)	DC-NC	1x70 mm ²
IK.117.06	(D1+A)-(D1+B)-(D1+D1)-(D2+A)-(D2+B) (D2+D2)-(N+A)-(N+B)-(N+N)	DC-NC	1x95 mm ²



Code	Material/Coating	Bolt	Cross Section
IK.117.24	(D1+A)-(D1+B)-(D1+D1)-(D2+A)-(D2+B) (D2+D2)-(N+A)-(N+B)-(N+N)	DC-NC	2x50 mm ²
IK.117.25	(D1+A)-(D1+B)-(D1+D1)-(D2+A)-(D2+B) (D2+D2)-(N+A)-(N+B)-(N+N)	DC-NC	2x70 mm ²
IK.117.26	(D1+A)-(D1+B)-(D1+D1)-(D2+A)-(D2+B) (D2+D2)-(N+A)-(N+B)-(N+N)	DC-NC	2x95 mm ²

MAIN MATERIAL
 A=Aluminium, B=Copper, D=Iron-Steel,
 F=Bronze, G=Gray Cast Iron,
 N=Stainless, P=Plastic, S=Brass

COATINGS
 1=Electrogalvanizing, 2=Hot Dip Galvanizing,
 3=Electrodeposited Copper, 4=Electrodeposited Tin,
 5=Electrodeposited Chromium-Nickel,
 6=Black Insulation, 7=Yellow-Green Insulation

SCREW NUT
 DC=Galvanizing,
 NC=Stainless,
 SC=Brass



CLIPS / CONDUCTOR HOLDER



Roof Conductor Holder

Code	Material/Coating	Bolt	Cross Section
IK.117.31	(D1+A)-(D1+B)-(D1+D1)-(D2+A)-(D2+B) (D2+D2)-(N+A)-(N+B)-(N+N)	DC-NC	25x3mm
IK.117.32	(D1+A)-(D1+B)-(D1+D1)-(D2+A)-(D2+B) (D2+D2)-(N+A)-(N+B)-(N+N)	DC-NC	35x3mm
IK.117.33	(D1+A)-(D1+B)-(D1+D1)-(D2+A)-(D2+B) (D2+D2)-(N+A)-(N+B)-(N+N)	DC-NC	45x3mm



Code	Material/Coating	Bolt	Cross Section
IK.118.04	(D1+A)-(D1+B)-(D1+D1)-(D2+A)-(D2+B)- (D2+D2)-(N+A)-(N+B)-(N+N)	DC-NC	1x50 mm ²
IK.118.05	(D1+A)-(D1+B)-(D1+D1)-(D2+A)-(D2+B) (D2+D2)-(N+A)-(N+B)-(N+N)	DC-NC	1x70 mm ²
IK.118.06	(D1+A)-(D1+B)-(D1+D1)-(D2+A)-(D2+B) (D2+D2)-(N+A)-(N+B)-(N+N)	DC-NC	1x95 mm ²



Code	Material/Coating	Bolt	Cross Section
IK.118.24	(D1+A)-(D1+B)-(D1+D1)-(D2+A)- (D2+B)-(D2+D2)-(N+A)-(N+B)-(N+N)	DC-NC	2x50 mm ²
IK.118.25	(D1+A)-(D1+B)-(D1+D1)-(D2+A)- (D2+B)-(D2+D2)-(N+A)-(N+B)-(N+N)	DC-NC	2x70 mm ²
IK.118.26	(D1+A)-(D1+B)-(D1+D1)-(D2+A)- (D2+B)-(D2+D2)-(N+A)-(N+B)-(N+N)	DC-NC	2x95 mm ²



Code	Material/Coating	Bolt	Cross Section
IK.118.31	(D1+A)-(D1+B)-(D1+D1)-(D2+A)- (D2+B)-(D2+D2)-(N+A)-(N+B)-(N+N)	DC-NC	25x3 mm
IK.118.32	(D1+A)-(D1+B)-(D1+D1)-(D2+A)- (D2+B)-(D2+D2)-(N+A)-(N+B)-(N+N)	DC-NC	35x3 mm
IK.118.33	(D1+A)-(D1+B)-(D1+D1)-(D2+A)- (D2+B)-(D2+D2)-(N+A)-(N+B)-(N+N)	DC-NC	45x3 mm

MAIN MATERIAL
 A=Aluminium, B=Copper, D=Iron-Steel,
 F=Bronze, G=Gray Cast Iron,
 N=Stainless, P=Plastic, S=Brass

COATINGS
 1=Electrogalvanizing, 2=Hot Dip Galvanizing,
 3=Electrodeposited Copper, 4=Electrodeposited Tin,
 5=Electrodeposited Chromium-Nickel,
 6=Black Insulation, 7=Yellow-Green Insulation

SCREW NUT
 DC=Galvanizing,
 NC=Stainless,
 SC=Brass



CLIPS / CONDUCTOR HOLDER

Conductor Holders



Code	Material/Coating	Bolt	Cross Section
IK.109.001	B-D1-D2-N	DC-NC	1x50 den 1x95mm ² kadar
IK.109.002	B-D1-D2-N	DC-NC	20x3 den 40x3mm kadar



Code	Material	Bolt	Cross-section
IK.111.04	(A+D1)-(A+D2)-(A+N)-(B+D1)-(B+D2) (B+N)-(D1+D1)-(D2+D2)-(N+N)	DC-NC	1x50 mm ²
IK.111.05	(A+D1)-(A+D2)-(A+N)-(B+D1)-(B+D2) (B+N)-(D1+D1)-(D2+D2)-(N+N)	DC-NC	1x70 mm ²
IK.111.06	(A+D1)-(A+D2)-(A+N)-(B+D1)-(B+D2) (B+N)-(D1+D1)-(D2+D2)-(N+N)	DC-NC	1x95 mm ²

CONNECTORS

2-Way Connector



Wire Dia.	Cu	Al
	Code	
8	UCC-208	UCA-208
10	UCC-210	UCA-210
12	UCC-212	UCA-212



MAIN MATERIAL
 A=Aluminium, B=Copper, D=Iron-Steel,
 F=Bronze, G=Gray Cast Iron,
 N=Stainless, P=Plastic, S=Brass

COATINGS
 1=Electrogalvanizing, 2=Hot Dip Galvanizing,
 3=Electrodeposited Copper, 4=Electrodeposited Tin,
 5=Electrodeposited Chromium-Nickel,
 6=Black Insulation, 7=Yellow-Green Insulation

SCREW NUT
 DC=Galvanizing,
 NC=Stainless,
 SC=Brass



CONNECTORS

4-Way Connector



Wire Dia.	Cu	Al
8	UCC-408	UCA-408
10	UCC-410	UCA-410
12	UCC-412	UCA-412

Jaw (Nail) Connector

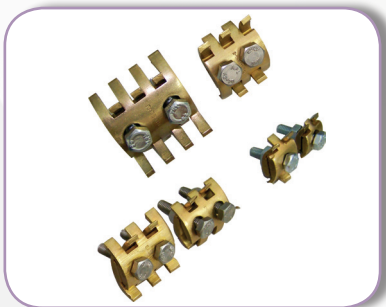

Code	Material	Cross-section (mm ²)
RTK.101.01	Brass	16
RTK.101.02	Brass	25
RTK.101.03	Brass	35
RTK.101.04	Brass	50
RTK.101.05	Brass	70
RTK.101.07	Brass	120

Pipe Clamps



Code	Material	Pipe Dia.	Cond. Dia
BES.114.01	Bronze- S.Steel	1/2"	8-12 mm
BES.114.02	Bronze- S.Steel	3/4"	8-12 mm
BES.114.03	Bronze- S.Steel	1"	8-12 mm
BES.114.04	Bronze- S.Steel	1"1/4	8-12 mm
BES.114.05	Bronze- S.Steel	1"1/2'	8-12 mm
BES.114.06	Bronze- S.Steel	2"	8-12 mm
BES.114.07	Bronze- S.Steel	2"1/2	8-12 mm
BES.114.08	Bronze- S.Steel	3"	8-12 mm

MAIN MATERIAL
 A=Aluminium, B=Copper, D=Iron-Steel,
 F=Bronze, G=Gray Cast Iron,
 N=Stainless, P=Plastic, S=Brass

COATINGS
 1=Electrogalvanizing, 2=Hot Dip Galvanizing,
 3=Electrodeposited Copper, 4=Electrodeposited Tin,
 5=Electrodeposited Chromium-Nickel,
 6=Black Insulation, 7=Yellow-Green Insulation

SCREW NUT
 DC=Galvanizing,
 NC=Stainless,
 SC=Brass



TEST CLAMPS

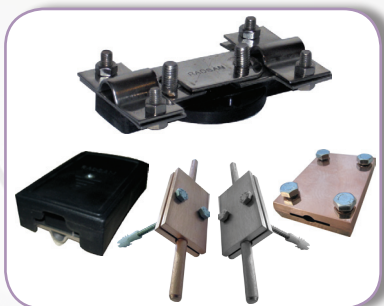

Code	Material/Coating	Wire Dia.
TK.105.01	Al, Cu, Cu+Sn	3/8"
TK.105.02	Al, Cu, Cu+Sn	7/16"
TK.105.03	Al, Cu, Cu+Sn	9/16"
TK.105.04	Al, Cu, Cu+Sn	8mm



Jaw (Nail) Connector

Code	Material/Coating	Wire Dia.
TK.104.01	Al- Cu-Brass	3/8"
TK.104.02	Al- Cu-Brass	7/16"
TK.104.03	Al- Cu-Brass	9/16"

EARTH BARS



Code	Material	Size(mm)	Hole Dia.
EBA.101.01	Cu	25x3x500	M8
EBA.101.02	Cu	30x3x500	M8
EBA.101.03	Cu	30x5x500	M8
EBA.101.04	Cu	30x5x210	M8
EBA.101.05	Cu	40x5x500	M8
EBA.102.01	Cu	60x5x500	M8
EBA.102.02	Cu	50x5x500	M8
EBA.102.03	Cu	100x6x500	M8

MAIN MATERIAL
 A=Aluminium, B=Copper, D=Iron-Steel,
 F=Bronze, G=Gray Cast Iron,
 N=Stainless, P=Plastic, S=Brass

COATINGS
 1=Electrogalvanizing, 2=Hot Dip Galvanizing,
 3=Electrodeposited Copper, 4=Electrodeposited Tin,
 5=Electrodeposited Chromium-Nickel,
 6=Black Insulation, 7=Yellow-Green Insulation

SCREW NUT
 DC=Galvanizing,
 NC=Stainless,
 SC=Brass



EARTH POINT ASSEMBLY

Body



Code	Material/Coating	Size(cm)
TPG.101.01	Plastic	14X12X10

Hook



Code	Material/Coating
TPK.102.01	Cu

Connector



Code	Material/Coating	Dia. (mm)
TPE.01	Cu	20

Connector



Code	Material/Coating	Dia. (mm)
TPE.03	Cu	<12

EARTH POINTS



Code M8	Code M10	Code M12	Connection Terminal
GPS.01	GPS.11	GPS.21	Dia. 20 mm
GPS.02	GPS.12	GPS.22	Dia. 8 mm
GPS.03	GPS.13	GPS.23	Dia. <12 mm

MAIN MATERIAL
 A=Aluminium, B=Copper, D=Iron-Steel,
 F=Bronze, G=Gray Cast Iron,
 N=Stainless, P=Plastic, S=Brass

COATINGS
 1=Electrogalvanizing, 2=Hot Dip Galvanizing,
 3=Electrodeposited Copper, 4=Electrodeposited Tin,
 5=Electrodeposited Chromium-Nickel,
 6=Black Insulation, 7=Yellow-Green Insulation

SCREW NUT
 DC=Galvanizing,
 NC=Stainless,
 SC=Brass



PROTECTED BAR



Code	Description	Thick x Width (mm)	Length (mm)	Bold
TSIC -101	SINGLE ROW HOLES WITH INSULATORS COVERED	3X30	300	NC
TSIC -102		3X30	500	NC
TSIC -103		3X30	1000	NC
TSIC -104		5X50	300	NC
TSIC -105		5X50	500	NC
TSIC -106		10X100	1000	NC
TSIC -107		10X100	300	NC
TSIC -108		10X100	500	NC
TSIC -109		10X100	1000	NC

(Fastners: Stainless Stell) - (Brackets: Stainless Stell / Cover Plexiglass / Pobonat, Number Of Holes Upon Customer Request, Labeling Is Available On The Cover

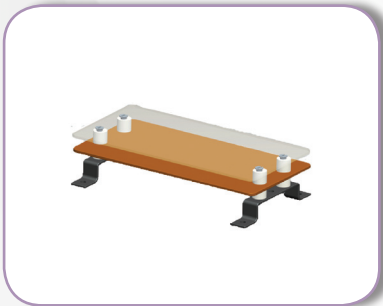

Code	Description	Thick x Width (mm)	Length (mm)	Bold
DSIC 202	DOUBLE ROW HOLES WITH INSULATORS COVERED	50x5	300	NC
DSIC 204		50x5	500	NC
DSIC 206		50x5	1000	NC
DSIC 207		100x10	200	NC
DSIC 208		100x10	300	NC
DSIC 209		100x10	400	NC
DSIC 210		100x10	500	NC
DSIC 212		160x10	1000	NC
DSIC 214		160x10	300	NC
DSIC 216		160x10	500	NC
DSIC 218		160x10	1000	NC

Cover : Plexiglass / Polycarbonat Number Of Holes Upon Customer Request, Labeling Is Available On The Cover

MAIN MATERIAL
 A=Aluminium, B=Copper, D=Iron-Steel,
 F=Bronze, G=Gray Cast Iron,
 N=Stainless, P=Plastic, S=Brass

COATINGS
 1=Electrogalvanizing, 2=Hot Dip Galvanizing,
 3=Electrodeposited Copper, 4=Electrodeposited Tin,
 5=Electrodeposited Chromium-Nickel,
 6=Black Insulation, 7=Yellow-Green Insulation

SCREW NUT
 DC=Galvanizing,
 NC=Stainless,
 SC=Brass



Telecommunications - Main Grounding Busbars TMGB

Code	Material	Size
TMGB-01	Tin Plated Copper	6x100x405 mm

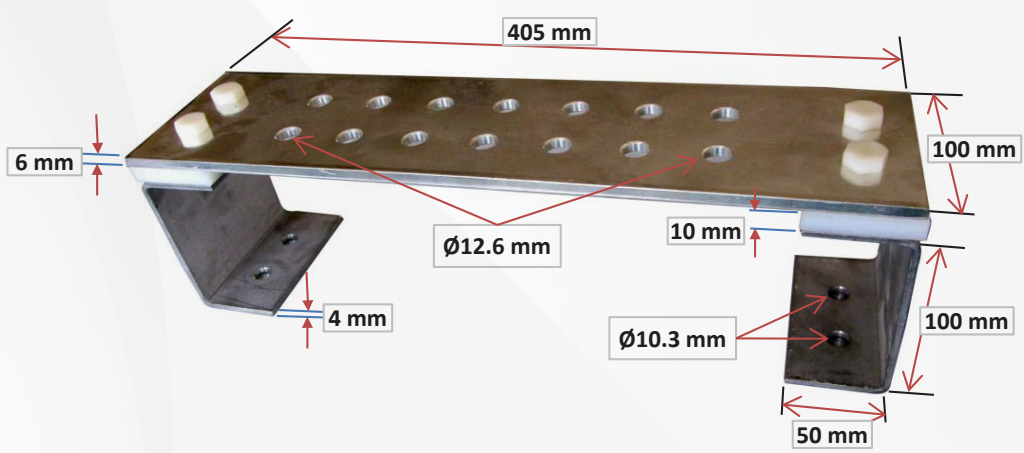
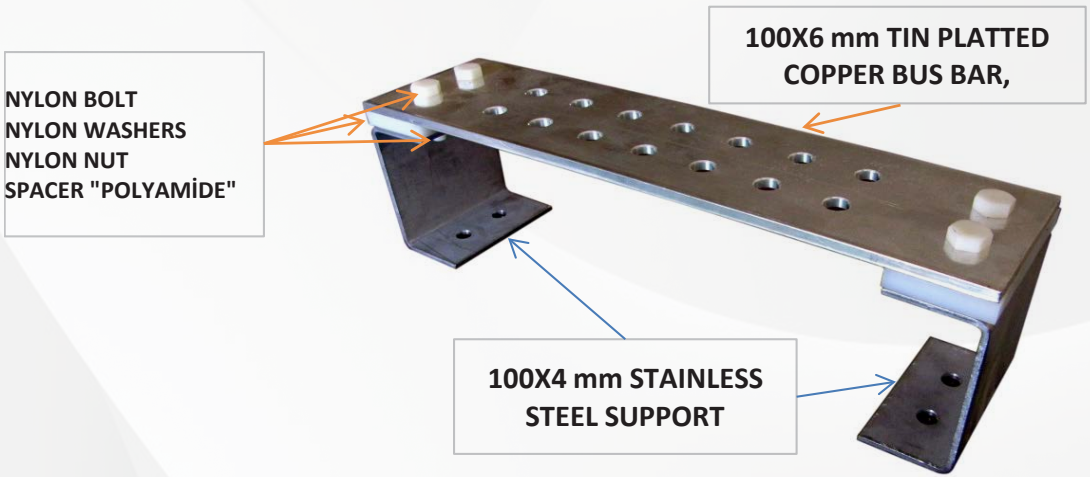



POINTED GROUND RODS



Code	Material/Coating	Dia.	Lenght
TES.16.1000	D1-D3-B-N-D2	16 mm	1000 mm
TES.16.1200	D1-D3-B-N-D2	16 mm	1200 mm
TES.16.1500	D1-D3-B-N-D2	16 mm	1500 mm
TES.16.1750	D1-D3-B-N-D2	16 mm	1750 mm
TES.16.2000	D1-D3-B-N-D2	16 mm	2000 mm
TES.16.2500	D1-D3-B-N-D2	16 mm	2500 mm
TES.16.3000	D1-D3-B-N-D2	16 mm	3000 mm
TES.16.3500	D1-D3-B-N-D2	16 mm	3500 mm
TES.18.1000	D1-D3-B-N-D2	18 mm	1000 mm
TES.18.1200	D1-D3-B-N-D2	18 mm	1200 mm
TES.18.1500	D1-D3-B-N-D2	18 mm	1500 mm
TES.18.1750	D1-D3-B-N-D2	18 mm	1750 mm
TES.18.2000	D1-D3-B-N-D2	18 mm	2000 mm
TES.18.2500	D1-D3-B-N-D2	18 mm	2500 mm
TES.18.3000	D1-D3-B-N-D2	18 mm	3000 mm
TES.18.3500	D1-D3-B-N-D2	18 mm	3500 mm
TES.20.1000	D1-D3-B-N-D2	20 mm	1000 mm
TES.20.1200	D1-D3-B-N-D2	20 mm	1200 mm
TES.20.1500	D1-D3-B-N-D2	20 mm	1500 mm
TES.20.1750	D1-D3-B-N-D2	20 mm	1750 mm
TES.20.2000	D1-D3-B-N-D2	20 mm	2000 mm
TES.20.2500	D1-D3-B-N-D2	20 mm	2500 mm
TES.20.3000	D1-D3-B-N-D2	20 mm	3000 mm
TES.20.3500	D1-D3-B-N-D2	20 mm	3500 mm

MAIN MATERIAL
 A=Aluminium, B=Copper, D=Iron-Steel,
 F=Bronze, G=Gray Cast Iron,
 N=Stainless, P=Plastic, S=Brass

COATINGS
 1=Electrogalvanizing, 2=Hot Dip Galvanizing,
 3=Electrodeposited Copper, 4=Electrodeposited Tin,
 5=Electrodeposited Chromium-Nickel,
 6=Black Insulation, 7=Yellow-Green Insulation

SCREW NUT
 DC=Galvanizing,
 NC=Stainless,
 SC=Brass



SECTIONAL GROUND RODS



Code	Material/Coating	Dia.	Lenght
TED.16.1000	D1-D3-B-N-D2	16 mm	1000 mm
TED.16.1200	D1-D3-B-N-D2	16 mm	1200 mm
TED.16.1500	D1-D3-B-N-D2	16 mm	1500 mm
TED.16.1750	D1-D3-B-N-D2	16 mm	1750 mm
TED.16.2000	D1-D3-B-N-D2	16 mm	2000 mm
TED.16.2500	D1-D3-B-N-D2	16 mm	2500 mm
TED.16.3000	D1-D3-B-N-D2	16 mm	3000 mm
TED.16.3500	D1-D3-B-N-D2	16 mm	3500 mm
TED.18.1000	D1-D3-B-N-D2	18 mm	1000 mm
TED.18.1200	D1-D3-B-N-D2	18 mm	1200 mm
TED.18.1500	D1-D3-B-N-D2	18 mm	1500 mm
TED.18.1750	D1-D3-B-N-D2	18 mm	1750 mm
TED.18.2000	D1-D3-B-N-D2	18 mm	2000 mm
TED.18.2500	D1-D3-B-N-D2	18 mm	2500 mm
TED.18.3000	D1-D3-B-N-D2	18 mm	3000 mm
TED.18.3500	D1-D3-B-N-D2	18 mm	3500 mm
TED.20.1000	D1-D3-B-N-D2	20 mm	1000 mm
TED.20.1200	D1-D3-B-N-D2	20 mm	1200 mm
TED.20.1500	D1-D3-B-N-D2	20 mm	1500 mm
TED.20.1750	D1-D3-B-N-D2	20 mm	1750 mm
TED.20.2000	D1-D3-B-N-D2	20 mm	2000 mm
TED.20.2500	D1-D3-B-N-D2	20 mm	2500 mm
TED.20.3000	D1-D3-B-N-D2	20 mm	3000 mm
TED.20.3500	D1-D3-B-N-D2	20 mm	3500 mm

MAIN MATERIAL
 A=Aluminium, B=Copper, D=Iron-Steel,
 F=Bronze, G=Gray Cast Iron,
 N=Stainless, P=Plastic, S=Brass

COATINGS
 1=Electrogalvanizing, 2=Hot Dip Galvanizing,
 3=Electrodeposited Copper, 4=Electrodeposited Tin,
 5=Electrodeposited Chromium-Nickel,
 6=Black Insulation, 7=Yellow-Green Insulation

SCREW NUT
 DC=Galvanizing,
 NC=Stainless,
 SC=Brass



COPPER PLATED STEEL EARTH ROD (1000µm)



Code	Material/Coating	Dia.	Lenght
TE 16.1000.1	(D+B)	16 mm	1000 mm
TE 16.1200.1	(D+B)	16 mm	1200 mm
TE 16.1500.1	(D+B)	16 mm	1500 mm
TE 16.1750.1	(D+B)	16 mm	1750 mm
TE 16.2000.1	(D+B)	16 mm	2000 mm
TE 16.3000.1	(D+B)	16 mm	3000 mm
TE 18.1000.1	(D+B)	18 mm	1000 mm
TE 18.1200.1	(D+B)	18 mm	1200 mm
TE 18.1500.1	(D+B)	18 mm	1500 mm
TE 18.1750.1	(D+B)	18 mm	1750 mm
TE 18.2000.1	(D+B)	18 mm	2000 mm
TE 18.3000.1	(D+B)	18 mm	3000 mm
TE 20.1000.1	(D+B)	20 mm	1000 mm
TE 20.1200.1	(D+B)	20 mm	1200 mm
TE 20.1500.1	(D+B)	20 mm	1500 mm
TE 20.1750.1	(D+B)	20 mm	1750 mm
TE 20.2000.1	(D+B)	20 mm	2000 mm
TE 20.3000.1	(D+B)	20 mm	3000 mm

COPPER PLATED STEEL EARTH ROD (3000µm)

Code	Material/Coating	Dia.	Lenght
TE.22.250.31	(D+B)	22 mm	3000 mm

MAIN MATERIAL
 A=Aluminium, B=Copper, D=Iron-Steel,
 F=Bronze, G=Gray Cast Iron,
 N=Stainless, P=Plastic, S=Brass

COATINGS
 1=Electrogalvanizing, 2=Hot Dip Galvanizing,
 3=Electrodeposited Copper, 4=Electrodeposited Tin,
 5=Electrodeposited Chromium-Nickel,
 6=Black Insulation, 7=Yellow-Green Insulation

SCREW NUT
 DC=Galvanizing,
 NC=Stainless,
 SC=Brass



CONNECTION BOX, PITS



RIP.001

Code	Material/Coating	Size
RIP.001	C	400x400x200 mm

Sipariş üzerine büyük ebatlarda yapılabilir, kapakları dahildir.
If ordered, it could be produced bigger sizes. The covers are included.



RIP.002

Code	Material/Coating	Size
RIP.002	D1-D2	400x400x400 mm

Sipariş üzerine büyük ebatlarda yapılabilir, kapakları dahildir.
If ordered, it could be produced bigger sizes. The covers are included.



RIP.003

Code	Material/Coating	Size
RIP.003	G	228x138x200 mm

Sipariş üzerine büyük ebatlarda yapılabilir, kapakları dahildir.
If ordered, it could be produced bigger sizes. The covers are included.



RIP.004

Code	Material/Coating	Size
RIP.004	P	300x190x200 mm

Sipariş üzerine büyük ebatlarda yapılabilir, kapakları dahildir.
If ordered, it could be produced bigger sizes. The covers are included.



RIP.005

Code	Material/Coating	Size
RIP.005	P	245x190x215 mm

Sipariş üzerine büyük ebatlarda yapılabilir, kapakları dahildir.
If ordered, it could be produced bigger sizes. The covers are included.



RIP.006

Code	Material/Coating	Size
RIP.006	C+G	600x600x400 mm

Sipariş üzerine büyük ebatlarda yapılabilir, kapakları dahildir.
If ordered, it could be produced bigger sizes. The covers are included.



ERITECH COPPERBONDED GROUND RODS STANDARD TYPE

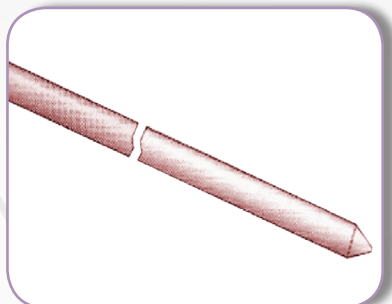

Meets BS6651/C33,8

UL467/ASTM A37/

UL467/ASTM A37/

Electrolytically copperbonded steel

Copper coating min. 250u according to standard UL467

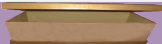
Code	Part No.	Ø inches	Appr. Ø mm	Nominal m	Lenght feet		Unit weight kg
... Non extending							
1,5M38	155010	3/8	9	1,2	4'	5	0,800
3,0M38	155050	3/8	9	3	10'	5	1,600
... Extending							
1,5M12	155070	1/2	12,5	1,5	5'	5	1,150
3,0M12	155110	1/2	12,5	3	5'	10	2,300
1,5M58	155250	5/8	14,2	1,5	5'	5	1,900
3,0M58	155290	5/8	14,2	3	10'	5	3,750
1,5M34	155430	3/4	17,2	1,5	5'	5	2,750
3M34	155470	3/4	17,2	3	10'	5	5,450

CADWELD





CADWELD® PLUS



Installation Is Easy!

4 Simple Steps For Permanently Welded Electrical Connections



1 Insert CADWELD® PLUS package into mould



2 Attach control unit termination clip to ignition strip



3 Press and hold control unit switch and wait for the ignition



4 Open the mould and remove the expended steel cup – no special disposal required

CADWELD PLUS for Grounding Applications

CADWELD PLUS Reference Code	Part No.	Size Identification Ring Color	Traditional Welding Material Part Number (Clear Cap)
15PLUSF20	165700	Black	15
25PLUSF20	165701	Red	25
32PLUSF20	165702	White	32
45PLUSF20	165703	Light Blue	45
65PLUSF20	165704	Dark Green	65
90PLUSF20	165705	Gray	90
115PLUSF20	165706	Orange	115
150PLUSF20	165707	Dark Blue	150
200PLUSF20	165708	Yellow	200
250PLUSF20	165709	Purple	250
300PLUSF20	165710	Light Green	use 2 x 150
400PLUSF20	165711	Brown	use 2 x 200
500PLUSF20	165712	Light Brown	500

CADWELD PLUS for Cathodic Applications

CADWELD PLUS Reference Code	Part No.	Size Identification Ring Color	Traditional Welding Material Part Number (Green Cap)
CA15PLUSF33	165713	Black	CA15/CA15S
CA25PLUSF33	165714	Red	CA25
CA32PLUSF33	165715	White	CA32
CA45PLUSF33	165716	Light Blue	CA45
CA65PLUSF33	165717	Dark Green	CA65

CADWELD PLUS Reference Code	Part No.	Size Identification Ring Color	Traditional Welding Material Part Number (Orange Cap)
CA25PLUSXF19	165722	Red	CA25XF19
CA32PLUSXF19	165723	White	CA32XF19
CA45PLUSXF19	165724	Light Blue	CA45XF19
CA65PLUSXF19	165725	Dark Green	CA65XF19

CADWELD PLUS for Cast Iron Applications

CADWELD PLUS Reference Code	Part No.	Size Identification Ring Color	Traditional Welding Material Part Number (Orange Cap)
25PLUSXF19	165718	Red	25XF19
32PLUSXF19	165719	White	32XF19
45PLUSXF19	165720	Light Blue	45XF19
65PLUSXF19	165721	Dark Green	65XF19

Gram weight PLUS welding material type i.e. 45PLUSF20

Accessories

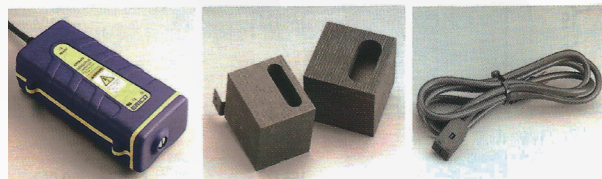

PLUSCU Baffle Cover Kit PLUSCULD
 ADWELD PLUS Patent Numbers 6,553,911 6,835,910 6,703,578

Reference Code	Part No.	Description
PLUSCU	165738	CADWELD PLUS Control Unit
PLUSCU15L	165745	CADWELD PLUS Control Unit with 15 ft. (4.6 meters) Lead
PLUSCULD	165739	CONTROL UNIT Replacement Lead 6 ft. (1.8 meters)
PLUSCULD15	165746	CONTROL UNIT Replacement Lead 15 ft. (4.6 meters)
MC2X2KIT	165740	Kit, Baffle Cover, Graphite - 2" X 2" Mould
MC25X3KIT	165744	Kit, Baffle Cover, Graphite - 2½" X 3" Mould
MC3X3KIT	165741	Kit, Baffle Cover, Graphite - 3" X 3" Mould
MC4X4KIT	165742	Kit, Baffle Cover, Graphite - 4" X 4" Mould

CADWELD PLUS Control Unit initiates the reaction of the metal crucible. The standard unit includes a 6-foot (1.8 meter) high temperature control unit lead. The lead attaches to the ignition strip using a custom made, purpose-designed termination clip.

After the termination clip is installed on the ignition strip, the installer pushes and holds the ignition button to start a charging and discharging sequence. Within a few seconds the control unit sends a predetermined voltage to the ignition strip and the reaction is initiated.



CADWELD® AND CADWELD® PLUS

Traditional CADWELD® & CADWELD® PLUS Welding Material

Welding Material Size	Traditional CADWELD					CADWELD PLUS				
	Reference code	Part No.	Unit Weight kg	Disk Type*		Reference code	Part No.	Unit Weight kg		
F20 Alloy - Clear Cap - Copper/Copper - Copper/Steel - Steel/Steel										
15	15	163590	20	0,015	19	15PLUSF20	165700	20	0,049	
25	25	163000	20	0,025	19	25PLUSF20	165701	20	0,063	
32	32	163010	20	0,032	19	32PLUSF20	165702	20	0,065	
45	45	163020	20	0,045	19	45PLUSF20	165703	20	0,086	
65	65	163030	20	0,065	19	65PLUSF20	165704	20	0,104	
90	90	163040	10	0,090	25	90PLUSF20	165705	10	0,158	
115	115	163050	10	0,115	25	115PLUSF20	165706	10	0,185	
150	150	163060	10	0,150	38	150PLUSF20	165707	10	0,217	
200	200	163070	10	0,200	38	200PLUSF20	165708	10	0,267	
250	250	163080	10	0,250	38	250PLUSF20	165709	10	0,353	
300	use (2) 150					300PLUSF20	165710	10	0,376	
400	use (2) 200					400PLUSF20	165711	10	0,480	
500	500	163090	10	0,500	38	500PLUSF20	165712	10	0,585	
F33 Alloy - Green Cap - Cathodic protection - Steel pipe										
15	CA15	163200	20	0,015	19	CA15PLUSF33	165713	20	0,049	
25	CA25	163210	20	0,025	19	CA25PLUSF33	165714	20	0,063	
32	CA32	163220	20	0,032	19	CA32PLUSF33	165715	20	0,065	
45	CA45	163230	20	0,045	19	CA45PLUSF33	165716	20	0,086	
65	CA65	163240	20	0,065	19	CA65PLUSF33	165717	20	0,104	
90	CA90	163250	10	0,090	25					
115	CA115	163260	10	0,115	25					
150	CA150	163270	10	0,150	38					
XF19 Alloy - Orange Cap - Cast Iron application										
25	25XF19	163280	20	0,025	19	25PLUSXF19	165718	20	0,063	
32	32XF19	163290	20	0,032	19	32PLUSXF19	165719	20	0,065	
45	45XF19	163300	20	0,045	19	45PLUSXF19	165720	20	0,086	
65	65XF19	163310	20	0,065	19	65PLUSXF19	165721	20	0,104	
90	90XF19	163320	10	0,090	25					
115	115XF19	163330	10	0,115	25					
XF19 Alloy - Orange Cap - Cathodic protection - Cast Iron pipe										
						CA25PLUSXF19	165722	20	0,063	
						CA32PLUSXF19	165722	20	0,065	
						CA45PLUSXF19	165722	20	0,086	
						CA65PLUSXF19	165722	20	0,104	

CADWELD

*Disk Type:

Welding material disks are supplied with "Traditional CADWELD" welding material. However, spare disks can be ordered as follows:

Welding Material size	Disk Type (Diameter - mm)	Reference Code	Part No.
15-65	19	DISC PACK21/19	141154
90-115	25	DISC PACK11/25	141156
150-500	38	DISC PACK11/38	141157



www.erico.com



CADWELD® MULTI

CADWELD® MULTI Connection Capabilities

Copper Cable/Solid to Copper Cable/Solid



SS SC PA TA XA GG GJ



PP PK GE PG GF GW XB

• Copper cable/solid sizes up to 1/0 (50 mm²) stranded or .40" (10 mm) diameter



TD TE TF

• Copper cable/solid sizes up to #3 (25 mm²) stranded or .26" (6,5 mm) diameter

Copper Cable/Solid/Strip to Rebar



RG RH RK RF RD

• Copper conductor sizes up to 1/0 (50 mm²) stranded or .40" (10 mm) diameter
 • Copper or steel strip/lug sizes up to 1" x .138" (30 x 3,5 mm)
 • Rebar sizes up to #3 (10 mm)

Copper Cable/Solid to Copper or Steel Strip/Lug

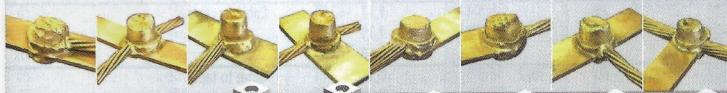

HA HC HS HT GL LA LJ LE

• Copper conductor sizes up to 1/0 (50 mm²) stranded or .40" (10 mm) diameter
 • Copper or steel strip/lug sizes up to 1" x .138" (30 x 3,5 mm)

Copper Strip to Copper Strip

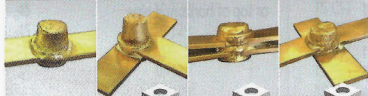

BB CG BG EB

• BB and CG 1" x (.020" - .118"), (30 x 3,5 mm)
 • BG and EB 1" x (.020" - .079"), (30 x 3 mm)

Galvanized Steel Strip to Galvanized Steel Strip

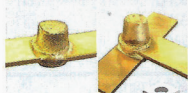

BB CG

• Galvanized steel strip sizes up to 1" x .138" (30 x 3,5 mm)

4 Easy steps for multiple, permanently welded, electrical connections



Step 1 Layer batting and variable conductor sizes to be welded into dry mold



Step 2 Close mold and drop metal disk in place



Step 3 Deposit welding material and tap bottom of container to release starting material



Step 4 Close the cover and ignite with flint ignitor. Open the mold after 10 seconds

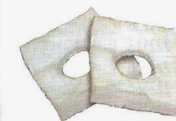

The CADWELD MULTI combines a versatile mold block and a range of gaskets (batting) to allow numerous different welded connections to be produced without the need to change the mold for each connection type.

The process is similar to the traditional CADWELD with one distinct difference... there is no need to change the mold for different connection types.

The whole process is complete in about one minute. The connection table details the gasket quantities required for each weld.

CADWELD MULTI Available Items

Description	Reference Code	Part No.		Unit Weight (kg)
Kit for 20 welds, in metallic box 14" x 13" x 6" (360 x 330 x 160 mm)	KITCDM01	167780	1	10.00
Kit for 20 welds using CADWELD PLUS, in metallic box (Control Unit sold separately) 14" x 13" x 11" (360 x 330 x 280 mm)	KITCDM01 PLUS	167781	1	11.50
Made from the following items which can be ordered separately:			Qty. in Kit	
Mould	CDM01	234720	1	1.000
Handle Clamp	FMCDM01	120882	1	1.100
Set of 33 battings/gaskets	SCDM01	120886	2	0.200
Welding material 90*	90	163040	2 boxes of 10	0.090
CADWELD PLUS Welding Material**	90PLUSF20	165705	2 boxes of 10	0.158
Toolset TS-6A, including: • gloves • cardcloth brush • soft brush • flint ignitor	TS6A	169930	1	0.490

* in KITCDM01 = Traditional CADWELD MULTI Kit
 ** in KITCDM01PLUS = CADWELD PLUS MULTI Kit



CADWELD®

Mould	Reference code	Part No.	Diameter		Section		Sizes mm	Unit weight kg	Remarks	
			Amm	Bmm	Amm ²	Bmm ²				
	SSC-W6	221008	8,0	8,0	50	50	1	1,37	Solid core cable horizontal splice	
	SSC-W8	221011	10,0	10,0	78,5	78,5	1	1,37		
	SSC-Y1	221004	6,4	6,4	25	25	1	1,37		Multi-strand cable to cable splice
	SSC-Y2	221006	7,6	7,6	35	35	1	1,37		
	SSC-Y3	221009	9,0	9,0	50	50	1	1,37		
	SSC-Y4	221021	11,0	11,0	70	70	1	1,37		
	SSC-Y5	221013	12,5	12,5	95	95	1	1,75		
SSC-Y6	221014	14,2	14,2	120	120	1	1,75			
	TAC-Y1	221025	6,4	6,4	25	25	1	1,37	Horizontal + cable to cable connection	
	TAC-Y2	221028	7,6	7,6	35	35	1	1,37		
	TAC-Y2-Y1	221063	7,6	6,4	35	25	1	1,37		
	TAC-Y3	222459	9,0	9,0	50	50	1	1,37		
	TAC-Y4	221035	11,0	11,0	70	70	1	1,37		
	TAC-Y4-Y2	221075	11,0	7,6	70	35	1	1,37		
	TAC-Y5	222461	12,5	12,5	95	95	1	1,37		
	TAC-Y5-Y6	225026	12,5	14,2	95	120	1	1,37		
	TAC-Y6	222463	14,2	14,2	120	120	1	1,57		
	TAC-Y6-Y4	221094	14,2	11,0	120	70	1	1,57		
	TAC-Y7	221051	15,9	15,9	150	150	1	1,57		
	TAC-Y8	221053	17,7	17,7	185	185	1	1,57		
		XAC-Y1	221135	6,4	6,4	25	25	1		1,37
XAC-Y2		221138	7,6	7,6	35	35	1	1,37		
XAC-Y3		221142	9,0	9,0	50	50	1	1,37		
XAC-Y4		221148	11,0	11,0	70	70	1	1,37		
XAC-Y5		221153	12,5	12,5	95	95	1	1,57		
XAC-Y6		221159	14,2	14,2	120	120	1	1,75		
	PGC-Y1	237901	6,4	6,4	25	25	1	1,37	Parallel horizontal conductors cable to cable	
	PGC-Y2	232556	7,6	7,6	35	35	1	1,37		
	PGC-Y3	232648	9,0	9,0	50	50	1	1,37		
	PGC-Y4	231342	11,0	11,0	70	70	1	1,37		
	PGC-Y4-Y1	236084	11,0	6,4	70	25	1	1,37		
	PGC-Y5	223943	12,5	12,5	95	95	1	1,57		
PGC-Y6	231692	14,2	14,2	120	120	1	1,57			
	PTC-Y1	221268	6,4	6,4	25	25	1	1,75	Parallel vertical conductors cable to cable	
	PTC-Y2	226545	7,6	7,6	35	35	1	1,75		
	PTC-Y3	221265	9,0	9,0	50	50	1	1,75		
	PTC-Y4	221258	11,0	11,0	70	70	1	1,75		
	PTC-Y5	221256	12,5	12,5	95	95	1	1,97		
	PTC-Y6	222115	14,2	14,2	120	120	1	1,97		
	PCC-Y1	223550	6,4	6,4	25	25	1	1,37	Cable to cable	
	PCC-Y3	222560	9,0	9,0	50	50	1	1,75		
	PCC-Y6	230199	14,2	14,2	120	120	1	1,97		
	LJP-Y1-BAK	234737	6,4		25	60	30x2	1	0,70	Cable to tape
	LJP-Y2-BAK	234738	7,6		35	60	30x2	1	0,70	
	LJP-Y3-BAK	234739	9,0		50	60	30x2	1	0,70	
	LJC-Y3-FAM	232933	9,0		50	250	50x5	1	1,37	
	LWP-Y3-BAK	234782	9,0		50	60	30x2	1	0,70	
	HAA-Y1	221609	6,4		25			1	0,31	Horizontal round or cable conductor to flat steel surface or top of horizontal pipe
	HAA-Y1-CA	221466	6,4		25			1	0,31	
	HAA-Y2	221607	7,6		35			1	0,31	
	HAA-A3	222689	8,0		40			1	0,31	
	HAA-Y3	221603	9,0		50			1	0,31	
	HAA-Y4	221534	11,0		70			1	0,45	
	HBA-B3	223044	4,9		14,5-16			1	0,31	Sleeve : H105 Tape to cable
	LEP-Y3-BAK	234759	9,0		50	60	30x2	1	0,60	
	VGC-Y1	228521	6,4		25			1	1,37	Cable through connections on vertical flat steel surface
	VGC-Y2	224815	7,6		35			1	1,37	
	VGC-Y3	222939	9,0		50			1	1,75	
	VGC-Y4	228347	11,0		70			1	1,75	
	VGC-Y5	223076	12,5		95			1	1,97	
	VGC-Y6	223609	14,2		120			1	1,97	
	VSC-Y3	221407	9,0		50			1	1,57	Cable to vertical steel surface
	VSC-Y4	221405	11,0		70			1	1,57	
	VSC-Y5	221404	12,5		95			1	1,57	
	VSC-Y6	221403	14,2		120			1	1,57	
	BMP-BAK	234429			60		30x2	1	0,87	
	BMP-CAJ	234426			75	75	25x3	1	0,87	
	G-BMP-DAJ	224123			87,5	87,5	25x3,5	1	0,87	Tape to tape
	BMP-CAJ-BAK	234736			75	60	25x3/30x2	1	0,60	
	EBP-BAK	225788			60	60	30x2	1	0,87	
	EB-BGP-BAK	234398			60	60	30x2	1	0,85	Tape to tape
	EBP-CAJ	234991			75	75	25x3	1	0,58	
	G-EBP-DAJ	223432			87,5	87,5	25x3,5	1	0,58	

CADWELD



www.erico.com



CADWELD®

Weld metal size required	Frame Page 53	Toolset Page 55	Scraper tools Page 55
45	L-160	TS CST	TP-3B
65	L-160	TS CST	TP-3B
32	L-160	TS CST	TP-3B
32	L-160	TS CST	TP-3B
45	L-160	TS CST	TP-3B
65	L-160	TS CST	TP-3B
90	L-160	TS CST	TP-7A
115	L-160	TS CST	TP-7A
32	L-160	TS CST	TP-3B
45	L-160	TS CST	TP-3B
45	L-160	TS CST	TP-3B
90	L-160	TS CST	TP-7A
90	L-160	TS CST	TP-7A
45	L-160	TS CST	TP-3B
115	L-160	TS CST	TP-7A
150	L-160	TS CST	TP-2A
150	L-160	TS CST	TP-2A
90	L-160	TS CST	TP-7A
200	L-160	TS CST	TP-2A
200	L-160	TS CST	TP-2A
45	L-160	TS CST	TP-3B
65	L-160	TS CST	TP-3B
90	L-160	TS CST	TP-7A
115	L-160	TS CST	TP-7A
150	L-160	TS CST	TP-2A
200	L-160	TS CST	TP-2A
45	L-160	TS CST	TP-3B
65	L-160	TS CST	TP-3B
90	L-160	TS CST	TP-7A
115	L-160	TS CST	TP-7A
90	L-160	TS CST	TP-7A
150	L-160	TS CST	TP-2A
200	L-160	TS CST	TP-2A
45	L-160	TS CST	TP-3B
65	L-160	TS CST	TP-3B
90	L-160	TS CST	TP-7A
115	L-160	TS CST	TP-7A
200	L-160	TS CST	TP-2A
250	L-160	TS CST	TP-2A
45	L-160	TS CST	TP-3B
90	L-160	TS CST	TP-7A
200	L-160	TS CST	TP-2A
65	L-161	TS CST	TP-5B
65	L-161	TS CST	TP-5B
90	L-161	TS CST	TP-5B
90	L-160	TS CST	TP-7A
90	L-161	TS CST	TP-5B
45	M-129	TS CST	TP-3B
32F33	M-129	TS CST	TP-3B
45	M-129	TS CST	TP-3B
45	M-129	TS CST	TP-3B
45	M-129	TS CST	TP-3B
65	M-129	TS CST	TP-3B
15F33	M-129	TS CST	TP-3B
25	M-129	TS CST	TP-3B
65	L-161	TS CST	TP-5B
45	L-160	TS CST	TP-3B
45	L-160	TS CST	TP-3B
115	L-160	TS CST	TP-7A
115	L-160	TS CST	TP-7A
150	L-160	TS CST	TP-2A
150	L-160	TS CST	TP-2A
90	L-160	TS CST	TP-7A
90	L-160	TS CST	TP-7A
115	L-160	TS CST	TP-7A
115	L-160	TS CST	TP-7A
65	L-161	TS CST	TP-5B
65	L-161	TS CST	TP-5B
90	L-161	TS CST	TP-2A
90	L-161	TS CST	TP-5B
90	L-161	TS CST	TP-5B
90	L-161	TS CST	TP-5B
65	L-161	TS CST	TP-5B
65	L-161	TS CST	TP-5B

CADWELD® PLUS Control Units

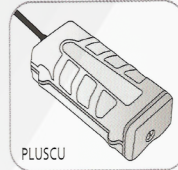

Reference code	Part No.	Description	Unit weight kg
PLUSCU	165738	Control Unit with 1,80 m lead	1 0,907
PLUSCU15L	165745	Control Unit with 4,60 m lead	1 1,088
PLUSCULD	165739	Replacement Lead 1,80 m long	1 0,146
PLUSCULD15	165746	Replacement Lead 4,60 m long	1 0,306

FLINT IGNITOR T320 AND SPARE FLINTS

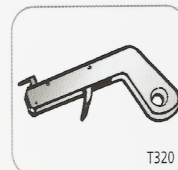

Reference code	Part No.	Unit weight kg
T320	165000	1 0,090
T320A	165010	10 0,015

BRUSHES

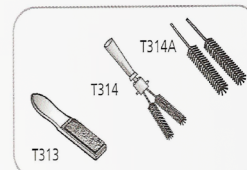

Reference code	Part No.	Unit weight kg
T313	165040	1 0,070
T314	165130	1 0,375
T314A	165270	1 0,070
KIT-120-3/4	165260	1 0,040



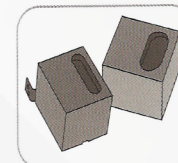













BAFFLE MOULD COVER



Reference code	Part No.	Unit weight kg
MC2X2KIT	165740	1 0,113
MC2.5X3KIT	165744	1 0,113
MC3X3KIT	165741	1 0,227
MC4X4KIT	165742	1 0,227



CADWELD®

Mould	Reference code	Part No.	Diameter		Section		Sizes mm		Unit weight kg	Remarks		
			Amm	Bmm	Amm ²	Bmm ²						
 CH	CHP-BAK	234733			60		30x2	1	0,70	Lug or tape to horizontal surface		
 CG	CGP-BAK	234732			60		30x2	1	0,70	Lug or tape to horizontal surface		
 CC	CCP-BAK	234734			60		30x2	1	0,70	Lug or tape to vertical surface		
 CF	CFP-BAK	232003			60		30x2	1	0,52	Lug or tape to vertical surface		
	CFP-CAJ	233366			75		25x3	1	0,70			
	G-CFP-DAJ	225147			87,5		25x3,5	1	0,70			
 BW	BWP-BAK	239887			60		30x2	1	0,90	Lug or tape to vertical surface		
 GR	GRC-P172-Y3	226567	17,2	9,0	232,4	50		1	1,75	Single stranded cable to top of ground rod		
	B-GRC-P143-Y3	238039	14,2	9,0	160,6	50		1	1,75			
 GT	GTC-P143-Y1	233901	14,2	6,4	160,6	25		1	1,75	Single stranded cable to top of ground rod		
	GTC-P143-Y2	229737	14,2	7,6	160,6	35		1	1,75			
	GTC-P143-Y3	225814	14,2	9,0	160,6	50		1	1,75			
	GTC-P143-Y4	232996	14,2	11,0	160,6	70		1	1,57			
	GTC-P143-Y5	223520	14,2	12,5	160,6	95		1	1,57			
	GTC-P172-Y1	228682	17,2	6,4	232,4	25		1	1,75			
	GTC-P172-Y2	226670	17,2	7,6	232,4	35		1	1,75			
	GTC-P172-Y3	226083	17,2	9,0	232,4	50		1	1,57			
	GTC-P172-Y4	227687	17,2	11,0	232,4	70		1	1,57			
	GTC-P172-Y5	227549	17,2	12,5	232,4	95		1	1,57			
	 CP	GTC-P190-ZG	223138	19	10,7	283,5	66,5		1		1,57	Tape to ground rod
		CPP-P143-BAK	234735	14,2		160,6	60	30x2	1		0,70	
CPP-P172-BAK		239694	17,2		232,4	60	30x2	1	0,68			
 GE	GEC-P128	232537	12,8	12,8	128,7	128,7		1	1,75	Horizontal ground round to ground rod splice		
	GEC-P143	237727	14,2	14,2	158	158		1	1,97			
 GF	GFC-P143-Y3	238544	14,2	9,0	160,6	50		1	1,75	Horizontal stranded cable to ground or other rod splice		
	GFC-P165-G2-B	238556	16,5	9,5	214	50		1	1,75			
 LA	LAC-Y1-BAH	224800	6,4		25	40	20x2	1	1,37	Stranded cable to lug or tape		
	LAC-Y1-CAJ	222501	6,4		25	75	25x3	1	1,37			
	LAC-Y2-BAH	224150	7,6		35	40	20x2	1	1,37			
	LAC-Y2-CAJ	221443	7,6		35	75	25x3	1	1,37			
	LAZ-Y3-BAK	234740	9,0		50	60	30x2	1	0,70			
	LAC-Y3-BAH	239534	9,0		50	40	20x2	1	1,37			
	LAC-Y3-BAJ	222122	9,0		50	50	25x2	1	1,37			
	LAC-Y3-CAJ	221455	9,0		50	75	25x3	1	1,37			
	LAC-L9-EAK-A	233795	10,0		60	120	30x4	1	1,75			
 CROWS FOOT edgewise	BJC-BAK-CROW	234770			60	60	30x2	1	2,20	Crowsfoot with edgewise tape		
 CROWS FOOT horizontal	BYC-BAK-CROW	234760			60	60	30x2	1	1,60	Crowsfoot with flat tape		
 RC	RCP-Y1	234581	10-40	6,4	S-2904B	25		1	0,68	Single stranded cable to rebar		
	RCP-Y2	234585	10-40	7,6	S-2904B	35		1	0,68			
	RCP-Y3	234582	10-40	9	S-2904B	50		1	0,68			
	RCP-Y4	234588	10-40	11	S-2904B	70		1	0,68			
	RCP-Y5	234592	10-40	12,5	S-2904B	95		1	0,68			
	RCP-Y6	234593	10-40	14,2	S-2904C	120		1	0,68			
 RT	RTP-Y1	234441	10-40	6,4	S-2904B	25		1	0,62	Single stranded cable to rebar		
	RTP-Y2	234444	10-40	7,6	S-2904B	35		1	0,62			
	RTP-Y3	234445	10-40	9	S-2904B	50		1	0,62			
	RTP-Y4	234447	10-40	11	S-2904B	70		1	0,62			
	RTP-Y5	234453	10-40	12,5	S-2904A	95		1	0,62			
	RTP-Y6	234454	10-40	14,2	S-3121	120		1	0,62			

CADWELD







CADWELD®

Weld metal size required	Frame Page 53	Toolset Page 55	Scraper tools Page 55
90	L-161	TS CST	TP-5B
90	L-161	TS CST	TP-5B
90	L-161	TS CST	TP-5B
65	L-161	TS CST	TP-5B
65	L-161	TS CST	TP-5B
65	L-161	TS CST	TP-5B
65	L-161	TS CST	TP-5B
90	L-160	TS CST	TP-7A
115	L-160	TS CST	TP-7A
90	L-160	TS CST	TP-7A
90	L-160	TS CST	TP-7A
115	L-160	TS CST	TP-7A
115	L-160	TS CST	TP-7A
90	L-160	TS CST	TP-7A
115	L-160	TS CST	TP-7A
115	L-160	TS CST	TP-7A
115	L-160	TS CST	TP-7A
115	L-160	TS CST	TP-7A
90	L-161	TS CST	TP-5B
115	L-161	TS CST	TP-3B
150	L-160	TS CST	TP-7A
150	L-160	TS CST	TP-2A
90	L-160	TS CST	TP-7A
115	L-160	TS CST	TP-7A
32	L-160	TS CST	TP-3B
45	L-160	TS CST	TP-3B
32	L-160	TS CST	TP-3B
45	L-160	TS CST	TP-3B
90	L-161	TS CST	TP-5B
45	L-160	TS CST	TP-3B
45	L-160	TS CST	TP-3B
65	L-160	TS CST	TP-3B
90	L-160	TS CST	TP-7A
115	L-160	TS CST	TP-2A
200	L-160	TS CST	TP-2A
45	L-161A	TS CST	TP-5B
45	L-161A	TS CST	TP-5B
65	L-161A	TS CST	TP-5B
90	L-161A	TS CST	TP-5B
90	L-161A	TS CST	TP-5B
90	L-161A	TS CST	TP-5B
45	SMK 21	TS CST	TP-5B
45	SMK 21	TS CST	TP-5B
90	SMK 21	TS CST	TP-5B
90	SMK 21	TS CST	TP-5B
90	SMK 21	TS CST	TP-5B
115	SMK 21	TS CST	TP-5B

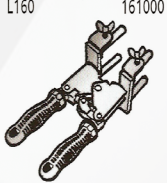
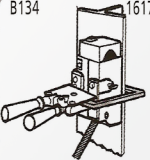
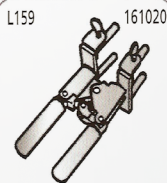
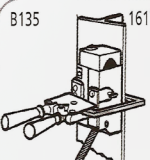
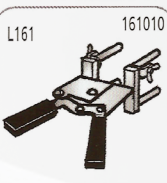
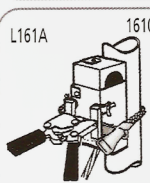
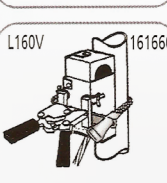
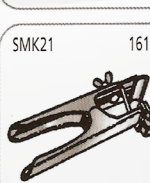
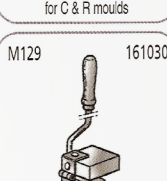
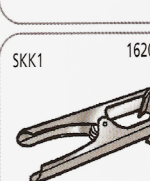
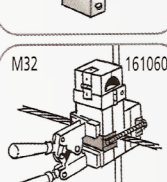
FRAMES

<p>L160 161000</p> 	<p>B134 161740</p>  <p>Clamp for frame L160</p>
<p>L159 161020</p> 	<p>B135 161780</p>  <p>Clamp for frame L159</p>
<p>L161 161010</p> 	<p>L161A 161090</p> 
<p>L160V 161660</p>  <p>Chain support clamp for C & R moulds</p>	<p>SMK21 161080</p> 
<p>M129 161030</p> 	<p>SKK1 162070</p> 
<p>M32 161060</p>  <p>Clamp for frame L160</p>	

Reference code	Part No.		Unit weight kg
L160	161000	1	1,185
L159	161020	1	1,325
L161	161010	1	0,380
B134	161740	1	0,360
B135	161780	1	0,414
L161A	161090	1	1,010
L160V	161660	1	1,775
M129	161030	1	0,315
M32	161060	1	0,880
SMK21	161080	1	0,670
SKK1	162070	1	0,500

CADWELD



CADWELD® KITS

CADWELD® MULTI Kit and CADWELD® PLUS MULTI Kit

Description	Reference Code	Part No.		Unit Weight (kg)
Kit for 20 welds, in metallic box 14" x 13" x 6" (360 x 330 x 160 mm)	KITCDM01	167780	1	10.00
Kit for 20 welds using CADWELD PLUS in metallic box (Control Unit sold separately) 14" x 13" x 11" (360 x 330 x 280 mm)	KITCDM01 PLUS	167781	1	11.50
Made from the following items which can be ordered separately: Qty. in Kit				
Mould	CDM01	234720	1	1.000
Handle Clamp	FMCDM01	120882	1	1.100
Set of 33 battings/gaskets	SCDM01	120886	2	0.200
Welding Material 90*	90	163040	2 boxes of 10	10 0.090
CADWELD PLUS Welding Material**	90PLUSF20	165705	2 boxes of 10	10 0.158
Toolset TS-6A, including: • gloves • cardcloth brush • soft brush • flint ignitor	TS6A	169930	1	0.490

* in KITCDM01 = Traditional CADWELD MULTI Kit
** in KITCDM01PLUS = CADWELD PLUS MULTI Kit

CADWELD® KITS

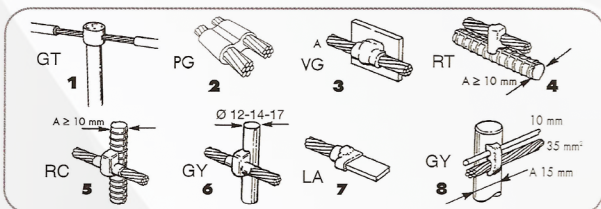

Reference code	Part No.	Figure	Welds per kit		Unit weight kg
••• Compact kit (20 welds)					
GT-P128	169310	1	20	1	2,110
PG-25/29	168050	2	20	1	2,015
PG-35	168060	2	20	1	2,225
VG-25/29	168090	3	20	1	2,265
VG-35	168100	3	20	1	2,265
GY-35	168180	6	20	1	2,320
GY-50	168190	6	20	1	2,600
••• Maxi kit (60 welds)					
PG-25/29-Z	168380	2	60	1	6,700
PG-35-Z	168390	2	60	1	7,450
PG-50-Z	168400	2	60	1	8,545
PG-70-Z	168410	2	60	1	8,630
VG25/29-Z	168440	3	60	1	6,525
VG35-Z	168450	3	60	1	6,785
VG50-Z	168460	3	60	1	7,200
VG70-Z	168470	3	60	1	11,000
RT-25-Z-10	169990	4	60	1	7,525
RT-35-Z-10	168830	4	60	1	7,525
RT-50-Z-10	168850	4	60	1	8,695
RC-35-Z-10	168890	5	60	1	6
RC-50-Z-10	168910	5	60	1	8,225
GY-35-Z	168630	6	60	1	7,050
GY-50-Z	168640	6	60	1	7,465
GY-95-Z	168660	6	60	1	10,560
LA-Y2-FAK	169600	7	60	1	16,750
GYV-35-Z-10	169890	8	60	1	6,745

GROUND NETWORK KITS FOR RAISED ACCESS FLOORS

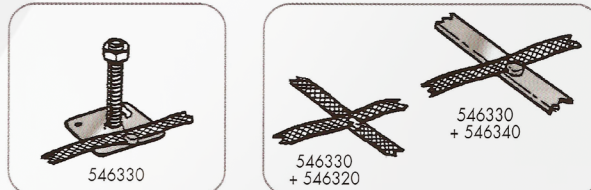

Reference code	Part No.	Description		Unit weight kg
••• Connections on lifting jack feet				
BK-CCR-2	546330	Basic kit, 200 welds	1	6,000
RK-CCR-2	546300	Consumable item, kit 200 welds	1	3,000
••• Additional connections (for braid 5 to 16 mm² and tape 30 x2)				
BB-CCR	546320	Braid/braid accessory	1	0,200
BF-CCR	546340	Braid/tape accessory	1	0,100

CATHODIC PROTECTION KITS

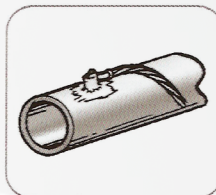

CADWELD DIRECT

Reference code	Part No.	Cable cross section mm²		Unit weight kg
••• Basic CADWELD kit 20 welds				
KIT CPD 2,5/16	167260	2,5 to 16	1	5,760
KIT CPD-25	167280*	25	1	5,700
KIT CPD-35	167300*	35	1	5,650
••• Consumable item CADWELD kit 20 welds				
CPD 2,5/16 PACK	167270	2,5 to 16	1	1,025
CPD-25 PACK	167290*	25	1	0,925
CPD-35 PACK	167310*	35	1	0,945

*Available upon request.

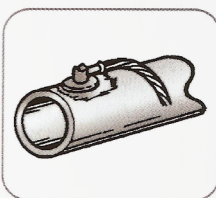

CADWELD BRAZE

Reference code	Part No.	Cable cross section mm²		Unit weight kg
••• Basic CADWELD kit 20 welds				
KIT CPB 2,5/16	167200	2,5 to 16	1	6,185
KIT CPB-25	167220*	25	1	6,095
KIT CPB-35	167240*	35	1	6,110
••• Consumable item CADWELD kit 20 welds				
CPB 2,5/16 PACK	167210	2,5 to 16	1	1,425
CPB-25 PACK	167230*	25	1	1,320
CPB-35 PACK	167250*	35	1	1,325

*Available upon request.





----- Price List -----

Page	Ref No	Price	Page	Ref No	Price
2	ULPC-3801		2	ULPC-3804	
2	ULPC-3802		2	ULPC-3805	
2	ULPC-3803		2	ULPC-3806	
2	ULPC-3804		2	ULPC-3807	
2	ULPC-3805		2	ULPC-3808	
2	ULPC-3806		2	ULPA-1201	
2	ULPC-3807		2	ULPA-1202	
2	ULPC-3808		2	ULPA-1203	
2	ULPA-1201		2	ULPA-1204	
2	ULPA-1202		2	ULPA-1205	
2	ULPA-1203		2	ULPA-1206	
2	ULPA-1204		2	ULPA-1207	
2	ULPA-1205		2	ULPA-1208	
2	ULPA-1206		2	ULPA-1201	
2	ULPA-1207		2	ULPA-1202	
2	ULPA-1208		2	ULPA-1203	
2	ULPC-1201		2	ULPA-1204	
2	ULPC-1202		2	ULPA-1205	
2	ULPC-1203		2	ULPA-1206	
2	ULPC-1204		3	ULPBC-3801	
2	ULPC-1205		3	ULPBC-3802	
2	ULPC-1206		3	ULPBC-5801	
2	ULPC-1207		3	ULPBC-5802	
2	ULPC-1208		3	ULPBA-1201	
2	ULPC-5801		3	ULPBA-1202	
2	ULPC-5802		3	ULPBA-5801	
2	ULPC-5803		3	ULPBA-5802	
2	ULPC-5804		3	PBCR-3801	
2	ULPC-5805		3	PBCR-1201	
2	ULPC-5806		3	PBCR-5801	
2	ULPC-5807		3	PBAR-1201	
2	ULPC-5808		3	PBAR-5801	
2	ULPA-5801		4	PAS-3801	
2	ULPA-5802		4	PAS-1201	
2	ULPA-5803		4	PAS-5801	
2	ULPA-5804		4	PAC-3801	
2	ULPA-5805		4	PAC-1201	
2	ULPA-5806		4	PAC-5801	
2	ULPA-5807		4	PAA-1201	
2	ULPA-5808		4	PAA-5801	
2	ULPC-3801		4	DPA-3801	
2	ULPC-3802		4	DPA-1201	
2	ULPC-3803		4	DPA-5801	



----- Price List -----

Page	Ref No	Price	Page	Ref No	Price
5	PBHC-3811		8	IK.107.04	
5	PBVC-3811		8	IK.107.05	
5	PBHC-5811		8	IK.107.06	
5	PBVC-5811		8	IK.107.07	
5	PBHC-3822		9	IK.124.01	
5	PBVC-3822		9	IK.124.02	
5	PBHC-5822		9	IK.124.03	
5	PBHC-5822		9	IK.124.04	
6	PBHA-1211		9	IK.124.05	
6	PBVA-1211		9	IK.124.06	
6	PBHA-5811		9	IK.124.07	
6	PBVA-5811		9	IK.126.01	
6	PBSSA-01		9	IK.126.02	
6	PBSSC-01		9	IK.126.03	
6	PBSSA-11		9	IK.126.04	
6	PBSSC-11		9	IK.126.05	
7	IKC-1101		9	IK.126.06	
7	IKC-1102		9	IK.126.07	
7	IKC-1103		9	IK.127.01	
7	IKC-1104		9	IK.127.02	
7	IKA-1101		9	IK.127.03	
7	IKA-1102		9	IK.127.04	
7	IKA-1103		9	IK.127.05	
7	IKA-1104		9	IK.127.06	
7	CFC-38		9	IK.127.07	
7	CFC-716		9	IK.134.04	
7	CFA-716		9	IK.134.05	
7	CFA-12		9	IK.134.06	
7	CFC-12		10	IKP.122.20.24	
7	CFA-916		10	IKP.122.20.25	
7	CFA-1932		10	IKP.122.20.26	
7	IK.102.01		10	IKP.122.20.31	
7	IK.102.02		10	IKP.122.20.32	
7	IK.102.03		10	IKP.122.25.24	
8	IK.104.01		10	IKP.122.25.25	
8	IK.104.02		10	IKP.122.25.26	
8	IK.104.03		10	IKP.122.25.31	
8	IK.115.31		10	IKP.122.25.32	
8	IK.115.32		10	IKP.122.30.24	
8	IK.115.33		10	IKP.122.30.25	
8	IK.115.04		10	IKP.122.30.26	
8	IK.115.05		10	IKP.122.30.31	
8	IK.115.06		10	IKP.122.30.32	



Price List

3Page	Ref No	Price	Page	Ref No	Price
10	IK.117.04		13	BES.114.03	
10	IK.117.05		13	BES.114.04	
10	IK.117.06		13	BES.114.05	
10	IK.117.24		13	BES.114.06	
10	IK.117.25		13	BES.114.07	
10	IK.117.26		13	BES.114.08	
11	IK.117.31		14	TK.105.01	
11	IK.117.32		14	TK.105.02	
11	IK.117.33		14	TK.105.03	
11	IK.118.04		14	TK.105.04	
11	IK.118.05		14	TK.104.01	
11	IK.118.06		14	TK.104.02	
11	IK.118.24		14	TK.104.03	
11	IK.118.25		14	EBA.101.01	
11	IK.118.26		14	EBA.101.02	
11	IK.118.31		14	EBA.101.03	
11	IK.118.32		14	EBA.101.04	
11	IK.118.33		14	EBA.101.05	
12	IK.109.001 / 002		14	EBA.102.01	
12	IK.111.04		14	EBA.102.02	
12	IK.111.05		14	EBA.102.03	
12	IK.111.06		15	TPG.101.01	
12	UCC-208		15	TPK.102.01	
12	UCC-210		15	TPE.01	
12	UCC-212		15	TPE.03	
12	UCA-208		15	GPS.01	
12	UCA-210		15	GPS.02	
12	UCA-212		15	GPS.03	
13	UCC-408		15	GPS.11	
13	UCC-410		15	GPS.12	
13	UCC-412		15	GPS.13	
13	UCA-408		15	GPS.21	
13	UCA-410		15	GPS.22	
13	UCA-412		15	GPS.23	
13	RTK.101.01		16	TSIC -101	
13	RTK.101.02		16	TSIC -102	
13	RTK.101.03		16	TSIC -103	
13	RTK.101.04		16	TSIC -104	
13	RTK.101.05		16	TSIC -105	
13	RTK.101.06		16	TSIC -106	
13	RTK.101.07		16	TSIC -107	
13	BES.114.01		16	TSIC -108	
13	BES.114.02		16	TSIC -109	



----- Price List -----

Page	Ref No	Price	Page	Ref No	Price
16	DSIC 202		19	TED.18.1000	
16	DSIC 204		19	TED.18.1200	
16	DSIC 206		19	TED.18.1500	
16	DSIC 207		19	TED.18.1750	
16	DSIC 208		19	TED.18.2000	
16	DSIC 209		19	TED.18.2500	
16	DSIC 210		19	TED.18.3000	
16	DSIC 212		19	TED.18.3500	
16	DSIC 214		19	TED.20.1000	
16	DSIC 216 = 218		19	TED.20.1500	
17	TMGB=01		19	TED.20.1750	
18	TES.16.1000		19	TED.20.2000	
18	TES.16.1200		19	TED.20.2500	
18	TES.16.1500		19	TED.20.3000	
18	TES.16.1750		19	TED.20.3500	
18	TES.16.2000		20	TE 16.1000.1	
18	TES.16.2500		20	TE 16.1200.1	
18	TES.16.3000		20	TE 16.1500.1	
18	TES.16.3500		20	TE 16.1750.1	
18	TES.18.1000		20	TE 16.2000.1	
18	TES.18.1200		20	TE 16.3000.1	
18	TES.18.1500		20	TE 18.1000.1	
18	TES.18.1750		20	TE 18.1200.1	
18	TES.18.2000		20	TE 18.1500.1	
18	TES.18.2500		20	TE 18.1750.1	
18	TES.18.3000		20	TE 18.2000.1	
18	TES.18.3500		20	TE 18.3000.1	
18	TES.20.1000		20	TE 20.1000.1	
18	TES.20.1200		20	TE 20.1200.1	
18	TES.20.1500		20	TE 20.1500.1	
18	TES.20.1750		20	TE 20.1750.1	
18	TES.20.2000		20	TE 20.2000.1	
18	TES.20.2500		20	TE 20.3000.1	
18	TES.20.3000		20	TE.22.250.31	
18	TES.20.3500		21	RIP.001	
19	TED.16.1000		21	RIP.002	
19	TED.16.1200		21	RIP.003	
19	TED.16.1500		21	RIP.004	
19	TED.16.1750		21	RIP.005	
19	TED.16.2000		21	RIP.006	
19	TED.16.2500		22	155010	
19	TED.16.3000		22	155050	
19	TED.16.3500		22	155070	



Price List

Page	Ref No	Price	Page	Ref No	Price
22	155110		24	65	
22	155250		24	90	
22	155290		24	115	
22	155430		24	150	
22	155470		24	200	
23	15PLUSF20		24	250	
23	25PLUSF20		24	use (2) 150	
23	32PLUSF20		24	use (2) 200	
23	45PLUSF20		24	500	
23	65PLUSF20		24	15PLUSF20	
23	90PLUSF20		24	25PLUSF20	
23	115PLUSF20		24	32PLUSF20	
23	150PLUSF20		24	45PLUSF20	
23	200PLUSF20		24	65PLUSF20	
23	250PLUSF20		24	90PLUSF20	
23	300PLUSF20		24	115PLUSF20	
23	400PLUSF20		24	150PLUSF20	
23	500PLUSF20		24	200PLUSF20	
23	25PLUSXF19		24	250PLUSF20	
23	32PLUSXF19		24	300PLUSF20	
23	45PLUSXF19		24	400PLUSF20	
23	65PLUSXF19		24	500PLUSF20	
23	CA15PLUS33		24	CA15	
23	CA25PLUS33		24	CA25	
23	CA32PLUS33		24	CA32	
23	CA45PLUS33		24	CA45	
23	CA65PLUS33		24	CA65	
23	CA25PLUSXF19		24	CA90	
23	CA32PLUSXF19		24	CA115	
23	CA45PLUSXF19		24	CA150	
23	CA65PLUSXF19		24	CA15PLUSF33	
23	PLUSCU		24	CA25PLUSF33	
23	PLUSCU15L		24	CA32PLUSF33	
23	PLUSCULD		24	CA45PLUSF33	
23	PLUSCULD15		24	CA65PLUSF33	
23	MC2X2KIT		24	25XF19	
23	MC25X3KIT		24	32XF19	
23	MC3X3KIT		24	45XF19	
23	MC4X4KIT		24	65XF19	
24	15		24	90XF19	
24	25		24	115XF19	
24	32		24	25PLUSXF19	
24	45		24	32PLUSXF19	



Price List

Page	Ref No	Price	Page	Ref No	Price
24	45PLUSXF19		26	PGC-Y1	
24	65PLUSXF19		26	PGC-Y2	
24	CA25PLUSXF19		26	PGC-Y3	
24	CA32PLUSXF19		26	PGC-Y4-Y1	
24	CA45PLUSXF19		26	PGC-Y5	
24	CA65PLUSXF19		26	PGC-Y6	
24	DISCPACK21/19		26	PTC-Y1	
24	DISCPACK11/25		26	PTC-Y2	
24	DISCPACK11/38		26	PTC-Y3	
25	KITCDM01		26	PTC-Y4	
25	KITCDM01PLUS		26	PTC-Y5	
25	CDM01		26	PTC-Y6	
25	FMCDM01		26	PCC-Y1	
25	SCDM01		26	PCC-Y3	
25	90		26	PCC-Y6	
25	90PLUSF20		26	LIB-Y1-BAK	
25	TS6A		26	LIB-Y2-BAK	
26	SSC-W6		26	LIB-Y3-BAK	
26	SSC-W8		26	LJC-Y3-FAM	
26	SSC-Y1		26	LWP-Y3-BAK	
26	SSC-Y2		26	LWP-Y3-BAK	
26	SSC-Y3		26	HAA-Y1	
26	SSC-Y4		26	HAA-Y1-CA	
26	SSC-Y5		26	HAA-Y2	
26	SSC-Y6		26	HAA-A3	
26	TAC-Y1		26	HAA-A3	
26	TAC-Y2		26	HAA-A4	
26	TAC-Y2-Y1		26	HAA-B3-CA	
26	TAC-Y3		26	LEB-Y3-BAK	
26	TAC-Y4		26	VGC-Y1	
26	TAC-Y4-Y2		26	VGC-Y2	
26	TAC-Y5		26	VGC-Y3	
26	TAC-Y5-Y6		26	VGC-Y4	
26	TAC-Y6		26	VGC-Y5	
26	TAC-Y6-Y4		26	VGC-Y6	
26	TAC-Y7		26	VSC-Y3	
26	TAC-Y8		26	VSC-Y4	
26	XAC-Y1		26	VSC-Y5	
26	XAC-Y2		26	VSC-Y6	
26	XAC-Y3		26	BMP-BAK	
26	XAC-Y4		26	BMP-CAJ	
26	XAC-Y5		26	G-BMP-DAJ	
26	XAC-Y6		26	BMP-CAJ-BAK	



Price List

Page	Ref No	Price	Page	Ref No	Price
26	EBP-BAK		28	GPC-P165-G2-B	
26	EB-BGP-BAK		28	LAC-Y1-BAH	
26	EBP-CAJ		28	LAC-Y1-CAJ	
26	G-EBP-DAJ		28	LAC-Y2-BAH	
27	PLUSCU		28	LAC-Y2-CAJ	
27	PLUSCU15L		28	LAZ-Y3-BAK	
27	PLUSCU15D		28	LAC-Y3-BAH	
27	PLUSCULD15		28	LAC-Y3-BAJ	
27	T320		28	LAC-Y3-CAJ	
27	T320A		28	LAC-L9-EAK-A	
27	T313		28	BJC-BAK-CROW	
27	T314		28	BYC-BAK-CROW	
27	T314A		28	RCP-Y1	
27	KIT-120-3/4		28	RCP-Y2	
27	MC2X2KIT		28	RCP-Y3	
27	MC2.5X3KIT		28	RCP-Y4	
27	MC3X3KIT		28	RCP-Y5	
27	MC4X4KIT		28	RCP-Y6	
28	CHP-BAK		28	RTP-Y1	
28	CGP-BAK		28	RTP-Y2	
28	CCP-BAK		28	RTP-Y3	
28	CFP-BAK		28	RTP-Y4	
28	CFP-CAJ		28	RTP-Y5	
28	G-CFP-DAJ		28	RTP-Y6	
28	BWP-BAK		29	L160	
28	GRC-P172-Y-3		29	L159	
28	B-GRC-P143-Y3		29	L161	
28	GTC-PT143-Y1		29	B134	
28	GTC-PT143-Y2		29	B135	
28	GTC-PT143-Y3		29	B161A	
28	GTC-PT143-Y4		29	L160V	
28	GTC-PT143-Y5		29	M129	
28	GTC-PT172-Y1		29	M32	
28	GTC-PT172-Y2		29	SMK21	
28	GTC-PT172-Y3		29	SKK1	
28	GTC-PT172-Y4		30	KITCDM01	
28	GTC-PT172-Y5		30	KITCDM01PLUS	
28	GTC-P190-2G		30	CDM01	
28	CPP-P143-BAK		30	FMCDM01	
28	CPP-172-BAK		30	SCDM01	
28	GEC-P128		30	90	
28	GEC-P143		30	90PLUSF20	
28	GEC-P143-Y3		30	TS6A	

Büro-Mağaza/Office-Shop:
İVOGSAN Ağaç Metal İşleri Sitesi
1122. Cadde 1434. Sokak No:1
06370, İvedik-ANKARA/TÜRKİYE
Tel : 0 312. 394 53 56 - 57
Fax: 0 312. 394 53 58



RADSAN

Fabrika/Factory:
Samsun Yolu 30. km
Hasanoğlan Sanayi Bölgesi
06780, Elmadağ-ANKARA/TÜRKİYE
Tel : 0 312. 865 23 51 pbx
Fax : 0 312. 865 25 92

web:www.radsan.com.tr • e-mail:radsan@radsan.com.tr • satis@radsan.com.tr